

TC22/23/24/25

825B029P

Compact capacitance level transmitter

Technical Data

Enclosure material:	Nylon + metallized Nylon
Mechanical installation:	Bajonet (to be insert into IP65 enclosure)
Mechanical protection:	IP50
Electrical connection:	2 x 6 pole plug-in connectors
Working temperature:	-30 to +80°C
Power supply depend to the model:	TC22 24Vdc, TC23 24Vac, TC24 115Vac, TC25 230Vac
Power consumption:	max 2,5W (1,5W Vdc)
Analog output:	4÷20mA max load 500 ohm
Measure range:	20pF÷10.000pF
Temperature compensation:	by ref. internal capacitor
Linearity:	0,5%
Calibration:	two push-buttons, for self-acquisition
LEDs display:	green LED flashing=measure Fix=calibration

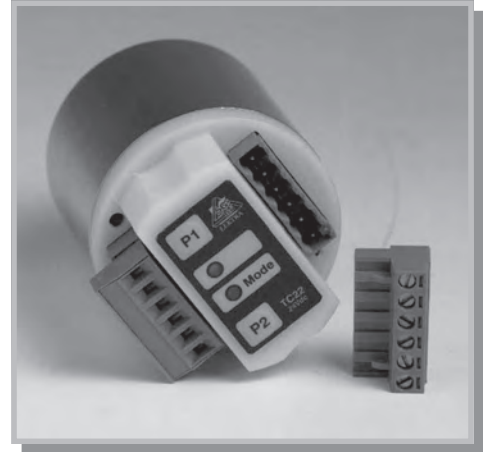

TC22-5 General

LEVEL 4÷20mA transmitter insert, digital technology, thermal drift compensation, two push-buttons for calibration. Local or remote calibration possibility.

COMPACT VERSION

fig.1

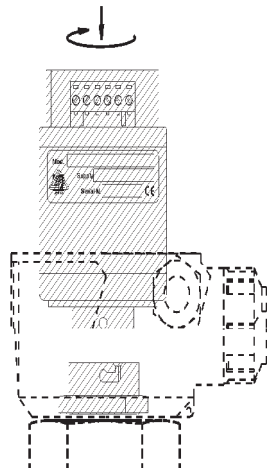

SEPARATE-ELECTRODE VERSION

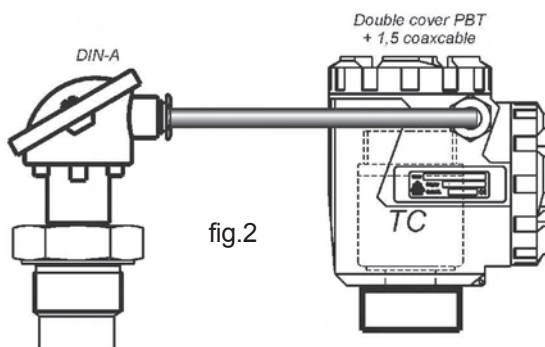

fig.2

TC22-5 Mechanical installation

The TC22-5 insert must be lodge into the IP65 capacitance-sensor head connection.

Important to screw tight the cover of the head connection and the cable gland in order to grant the sensor IP65.

Thanks to the bajonet fixing-system, to insert or remove the TC22-5 from the head connection need to push and rotate.

Rotate clock-wise to fix into the head

Rotate reverse-clock-wise to remove from the head

fig.3

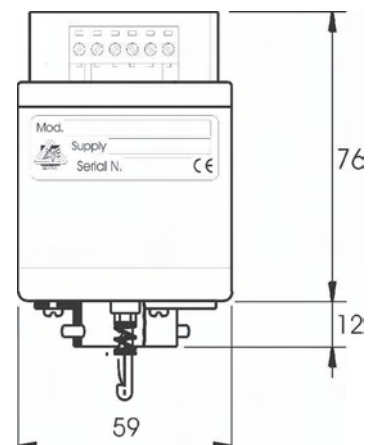

TC22-5 Electrical Connections

The TC22-5 capacitance transmitters have the following power-supply, electrical connections:

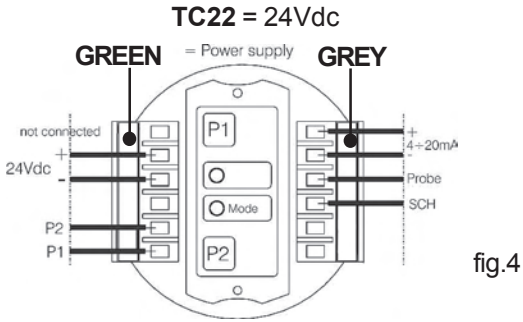

fig.4

TC23 = 24Vac, TC24 = 115Vac, TC25 = 230Vac

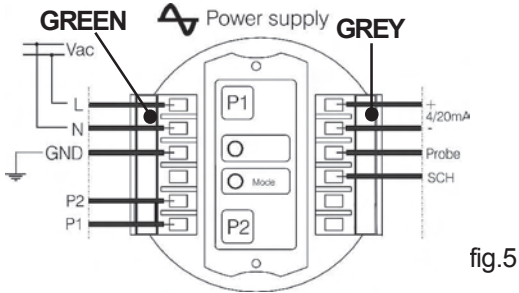
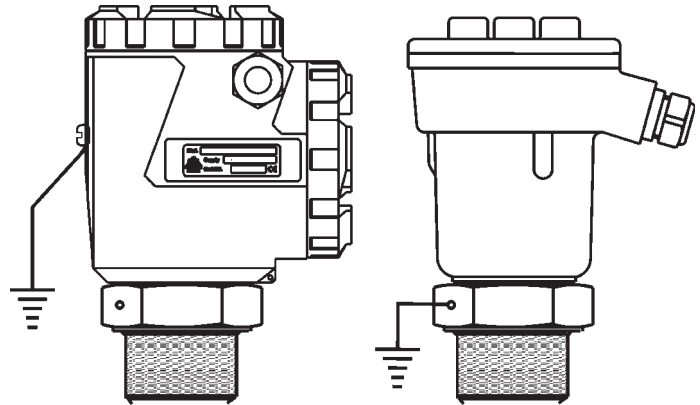
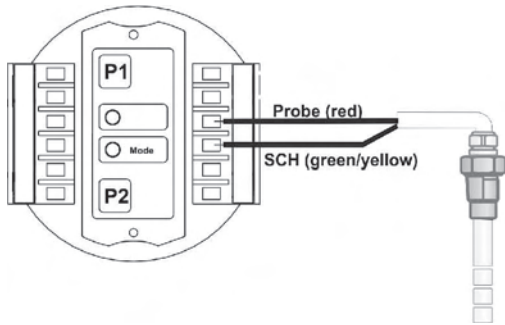

fig.5

Connecting the coaxial cable for probes version with electronic separate from the electrode



The current consumption is less than 1,5W for Vdc power supply and 2,5W for Vac power supply.

The TC22-59 capacitance transmitters are lodged into the sensor capacitance head connections; remove the cover unscrewing and opening the upper part, gain the access to two 6-pole plug-in connectors. Electrical connection must be made with a multi-wires round cable of proper diameter, otherwise the seal of the cable gland may be impaired. No special cable or coax-cable are requests for compact version, and no practice distance limits. For the Vdc power supply take in consideration that the negative of the power supply is electrically connected to the negative output current. For the Vac power supply versions, from the power supply and the output current there is a galvanically separation. A special J-box with P1 and P2 calibration push buttons built-in is available on request for remote-calibration.

Always connect the electrode to vessel ground (PA). For this purpose there is a terminal on the side of the housing or on the mechanical connection. This connection is also used to supply the ground reference potential as well as to drain off electrostatic charges.

TC22-5 Remote Calibration

If the installation of the capacitance sensor is lodged where in not easy the calibration using the P1 and P2 into the head connection, a remote calibration will be possible by means a special junction-box.

The available J-box is IP65 and it has inside P1, P2 keys that can make the same functions of the P1 and P2 keys on the TC22-5.

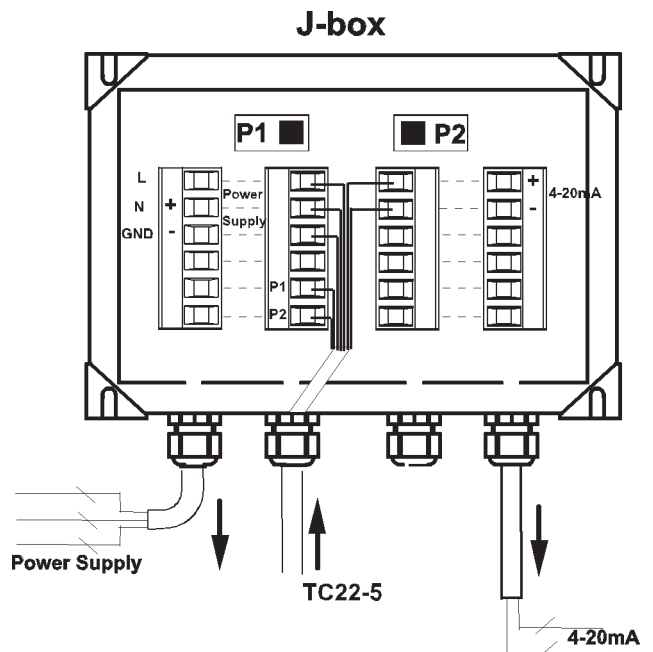

fig.6

TC22-5 4÷20mA Calibration

The TC22-5 calibration can be made by means the P1 and P2 push-buttons in two different procedures:

To calibrate, needs to lodge the "TC22-25" into the head connection of the capacitance sensor installed into the vessel or tank in which needs the level measurement.

Depends to the possibility to reach easily 0% and 100% level is possible to use:

"Full-Empty Calibration"

or, when 0% and 100% level can't be reached

"High and Low-point Calibration" procedure can be used, see fig.8.

Important!

The calibration can be done first with empty and than with full (as the above procedure) or first with full and than with empty as well.

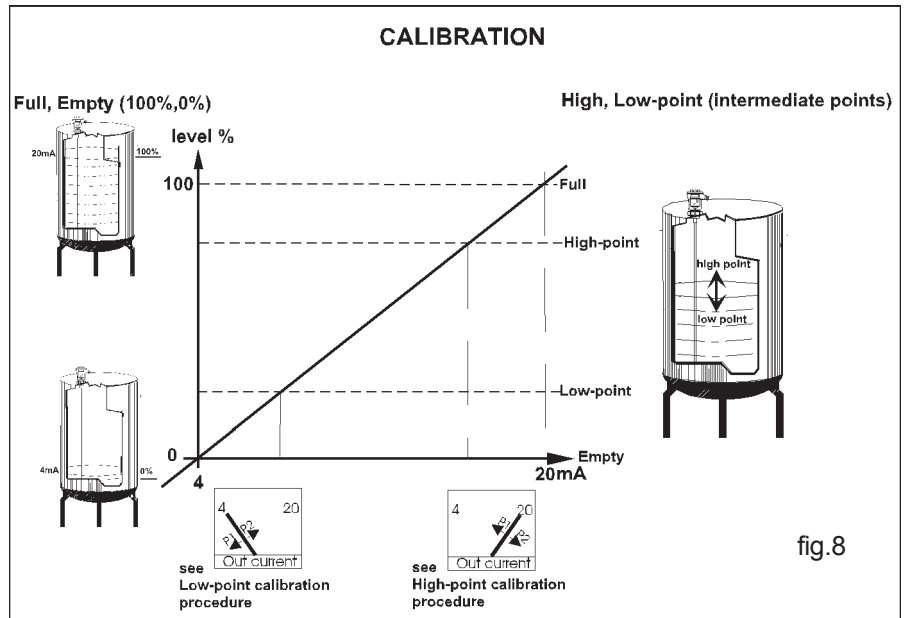

fig.8

Full, Empty Calibration(fig.9)

The TC22-5 transmitter can be calibrate in respectively at the level of 0% and 100% level, in order to memorise the relevant capacity electronically.

In the measuring mode, the TC has the Mode LED flashing.

To calibrate 0% (4mA) needs to have the level at the 0%.

Press simultaneously P1 and P2, release them and verify that "Mode led" will stay fix lightened.

Press two times P1. The measured capacity has been memorised and associated to 4mA output.

Press simultaneously P1 and P2 again to switch in measure mode (Mode led flashing).

To calibrate 100% (20mA) needs to have the level at the 100%.

Press simultaneously P1 and P2, release them and verify that "Mode led" will stay fix lightened.

Press two times P2. The measured capacity has been memorised and associated to 20mA output.

Press simultaneously P1 and P2 again to switch in measure mode (Mode led flashing).

Full(100%), Empty(0%) Calibration

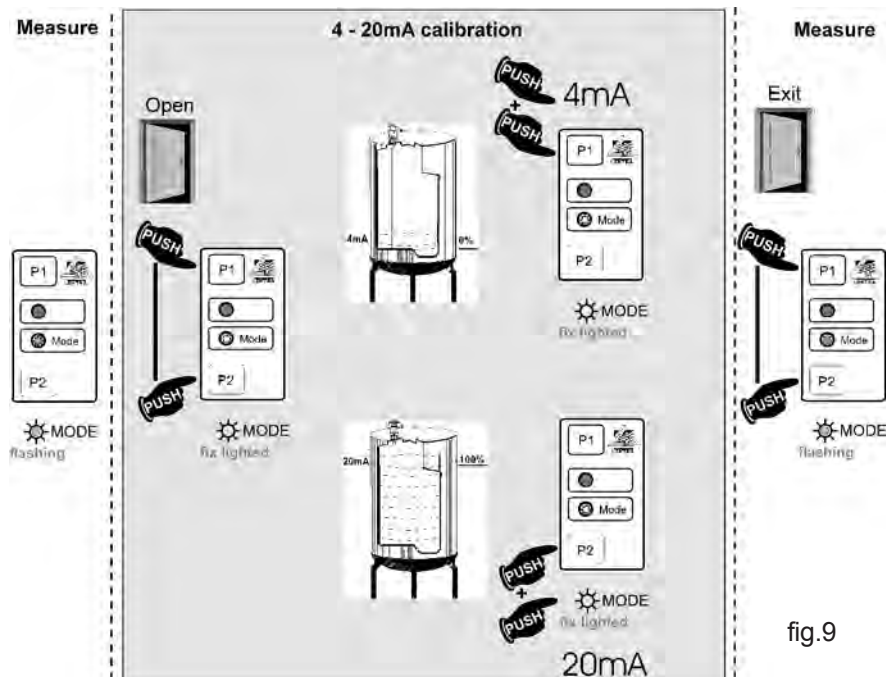

fig.9

