

SOP010RB BOARD IN RAIL BOX CONTAINER

Technical characteristics

Power supply	230Vac (15mA) (green led)
Consumption	3,2VA max
Stocking temperature	-20°C ÷ +70°C
Working temperature	0÷50°C
Max. pressure level	1mt (0÷1000mm H ₂ O), or 3mt (0÷3000mm H ₂ O)
Analogue outputs	0÷10V 0/4÷20mA (preset by μ switch), RL max 500 Ω
Linearity	0,5% of Fsd.
Intervention threshold of digital outputs	n° 4 rel led relays (red led)
Relays contacts	5A- 250V resistive load
Threshold intervention hysteresis	1 %
Dimensions	H = 100mm (110 with connector) - P = 120mm - L = 45mm
Weight	390 g. max.
Fastening	on DIN guide

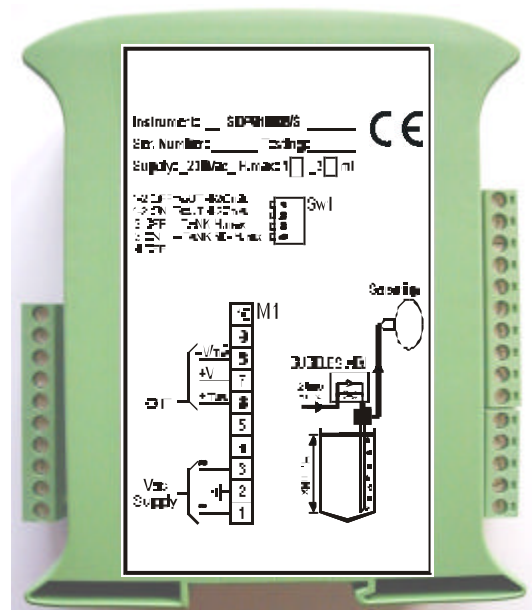
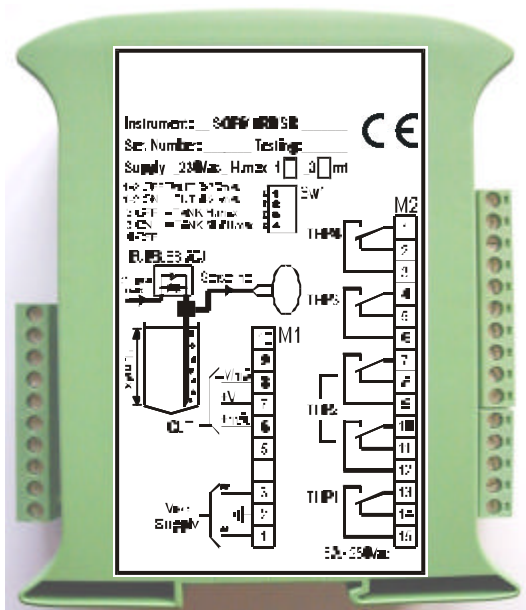

SOP010RB CONFIGURED AS PNEUMATIC LEVEL

Configurations

The configurations of sop010 for pneumatic level control are two:

- **SOP010RB / S** = Pneumatic level control with integrated sensor, with 0-10V, 0-20mA or 4-20mA output.
- **SOP010RB / SR** = Pneumatic level control with integrated sensor, with 0-10V, 0-20mA or 4-20mA output and 4 relays thresholds with exchange contact.

It's possible to have analogical output in volts or mA. As far as the mA output, it can be configured for 0-20mA or 4-20mA by dip-switch located near the pneumatic sensor. The board is calibrated in the factory to a height of 1 mt. corresponding to 100% of the tanks capacity, with 0-10V output.

Dip-switch Configuration:

- for 0-20 mA output, set 1-2 of SW1 to OFF
- for 4-20 mA output, set 1-2 of SW1 to ON
- for lower tank at approx. 60cm, set 3 of SW1 to ON and recalibrate the board.

Pneumatic connections

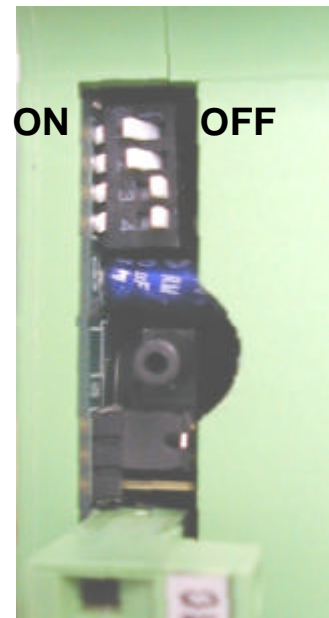
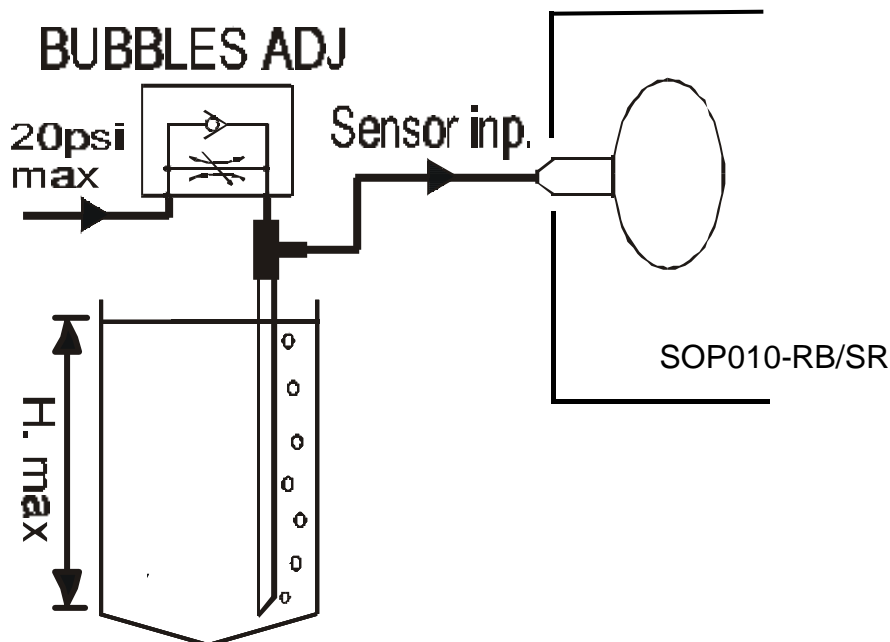

Electric connections

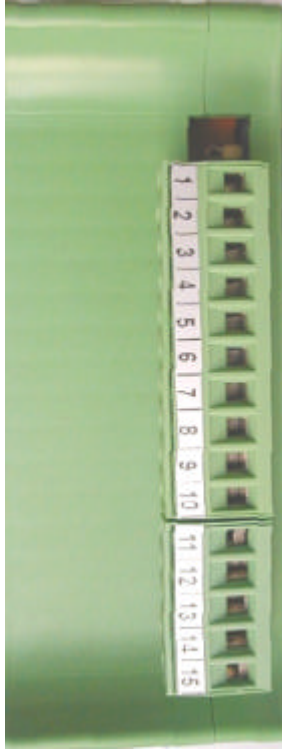
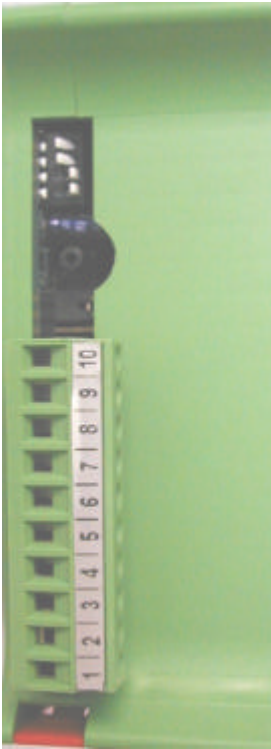
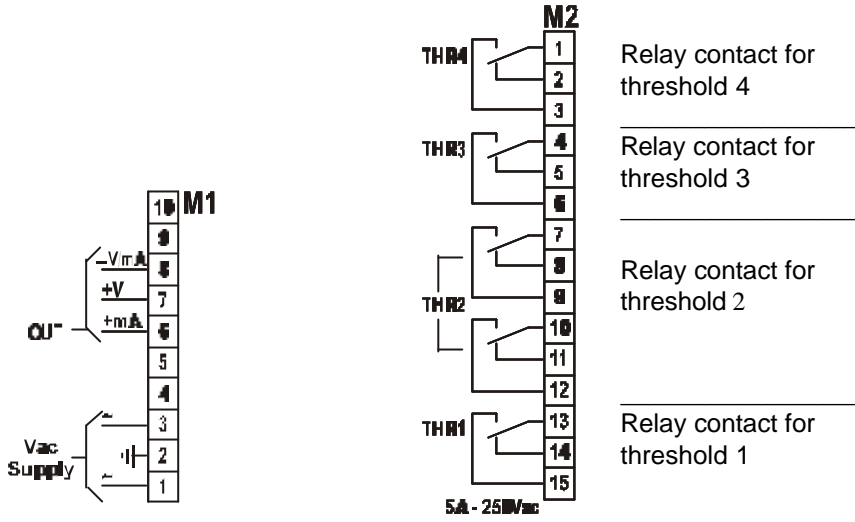

Analogical output calibration:

- Start calibration with 3 of SW1 set to OFF, if the max. output of 10V with full tank can't be achieved, set 3 of SW1 to ON and recalibrate the "ZERO" with P1 and the maximum with P2.
- For volt output, connect a voltmeter in parallel to the output, between the lugs 8 (-V/mA) and 7 (+V) of M1:
 - Take the tank to the empty condition, set the zero trimmer (Z) as to have aprx. 15/20mV output.
 - Fill up the tank up to 100%, set the max. trimmer (G), until a 10V reading. This operation must be done with dip-switch 3 of SW1 set to OFF and if the value of 10V can't be reached, set it to ON, repeating the calibration.
- For the mA output, connect a milliamperometer in series with the output, between 6 (+mA) of M1 and the load (or disconnect the output and connect the milliamperometer in parallel between 8 (-VmA) and 6 (+mA) of M1, set 1-2 of SW1 to OFF for the 0-20mA range, or 1-2 to ON for the 4-20mA range:
 - Take the tank to the empty condition, set the zero trimmer (Z) as to have aprx. 0.15/0.2mA (with SW1 set to OFF) or 4mA (with SW1 set to ON).
 - Fill up the tank up to 100%, set the max. trimmer (G), until a 20mA reading.. This operation must be done with dip-switch 3 of SW1 set to OFF and if the value of 10V can't be reached, set it to ON, repeating the calibration.

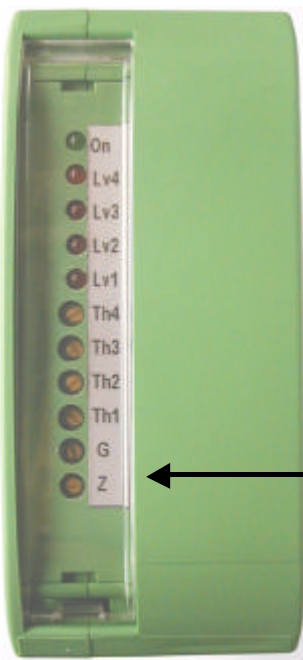

- G = Max. output calibration trimmer (V / mA)
- Z = Zero calibration Trimmer (empty).

Calibration of intervention theshold

After calibration of the analogical output, calibrate the intervention thesholds of the relay outputs.

Take the tanks level to the desired point of relay intervention and turn the relevant trimmer until the threshold led ligths off.

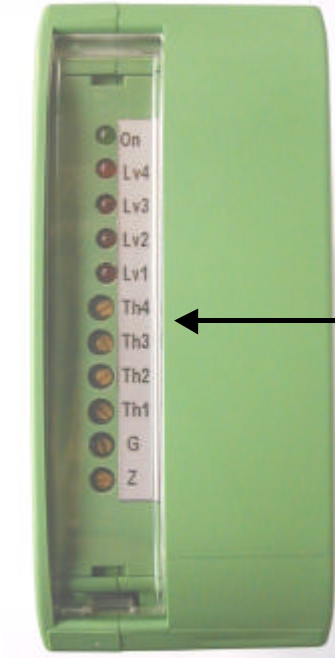

- Lv4 = On, level 4 (overflow) reached.
- Lv3 = On, level 3 (high) reached.
- Lv2 = On, level 2 (medium) reached.
- Lv1 = On, level 1 (empty or min.) reached.
- Th4 = Calibrates level Lv4 theshold (overflow).
- Th3 = Calibrates level Lv3 theshold (high).
- Th2 = Calibrates level Lv2 theshold (medium).
- Th1 = Calibrates level Lv1 theshold (empty or min.).

Dimensions

